

T658



**AUSTRALIAN MADE.
WORLD'S BEST.**



Sloping bonnet profile offering great all round visibility.

Legendary Kenworth cab appointments featuring luxurious colour co-ordinated trim and aircraft style instrumentation.

Large external air cleaners, with twin stage cyclonic action for maximum cleaning of intake air in outback conditions.

Choice of 36" or 50" modular sleeper boxes mounted to the chassis or suspended sub-frame.

Large storage compartments each side under the sleeper bunk and in the centre, with optional rear access.

Choice of Caterpillar or Cummins engines up to 625 hp to meet 2008 engine emission standards.

Durable grille and exterior fittings.

Long perforated steps allow plenty of choice on where to put your feet and the perforations allow mud to be scraped off and drop through.

Kenworth's T658 is a big, strong truck developed for big, tough Australian jobs. This is the truck for heavy long hauls, on the highway or the roughest outback tracks.

Long, reliable service is delivered in the most extreme operating conditions Australasia can throw at it, all with the highest levels of driver comfort and safety.

And the T658 has the versatility and power to operate in any application, ranging from general freight to logging, mining or livestock haulage, on or off the highway, in single or multiple trailer configurations.

Stainless clad aluminium bumper or optional bullbar are factory fitted so that towing points are integrated into the chassis structure. FUPS device is also available.

Cooling packages specifically designed to meet Australia's toughest conditions.

Remote keyless entry.

Custom engineered fuel/oil tanks available in round or rectangular configuration.

The widest range of specialist heavy duty rear axles.

Vehicle is shown with optional accessories. Images are shown for illustrative purposes only.

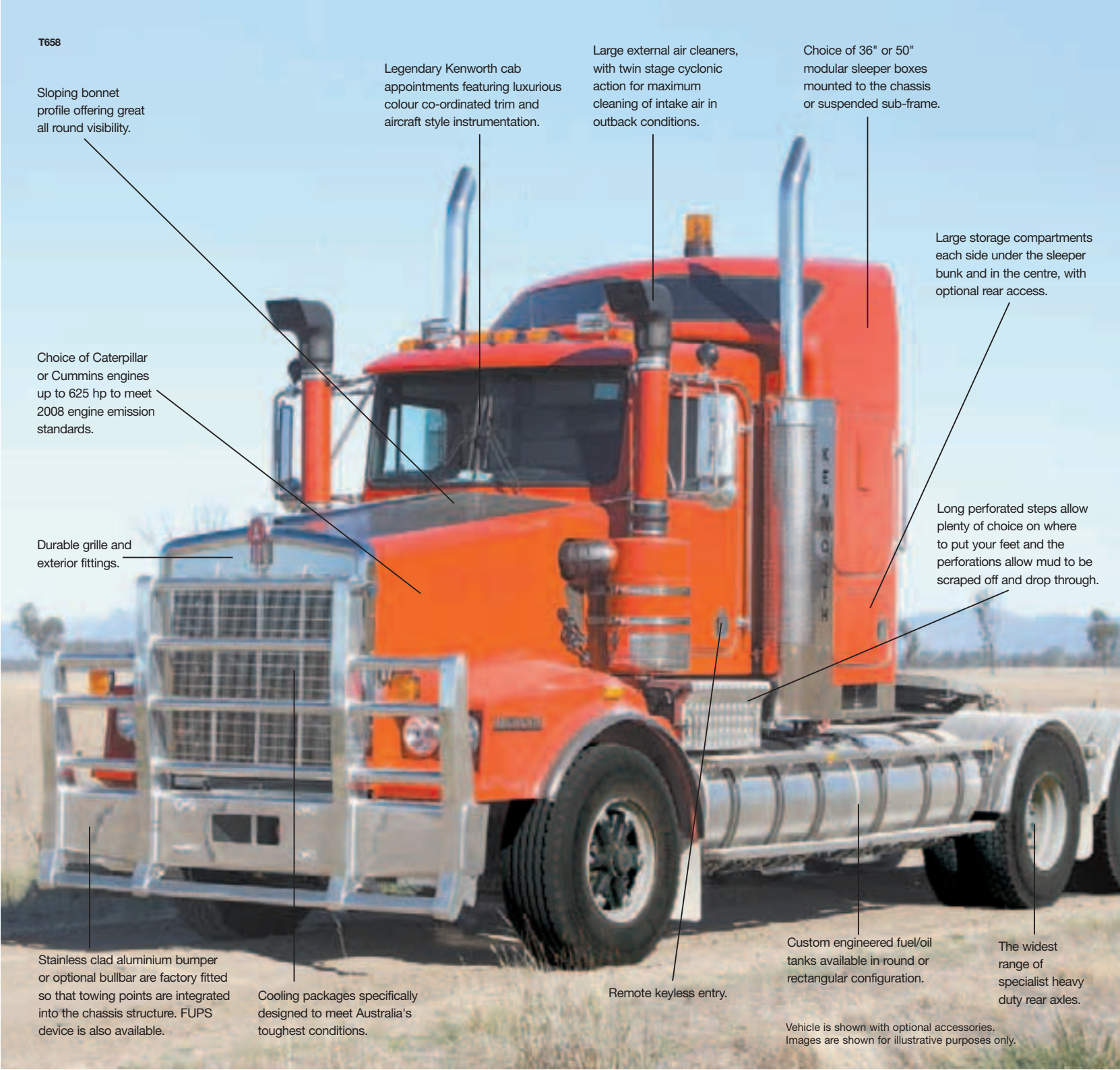



The T658 has been engineered from the ground up for the ultimate in trucking strength and durability.

Tough

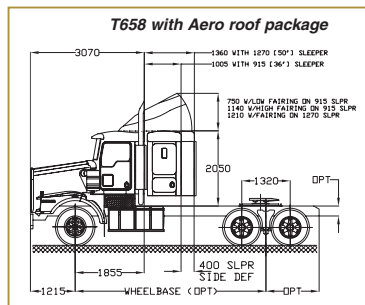
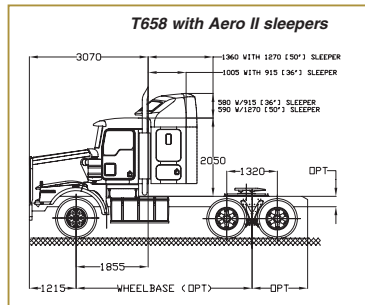
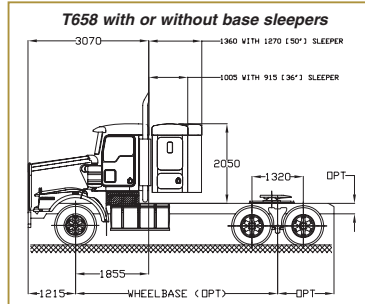

Powerful low emission performance

From 1 January 2008, all trucks manufactured for Australia have to meet the new ADR 83 standards for noise emissions and ADR80/02 standards for exhaust NOx and particulate emissions.

Kenworth has responded to these challenges with tens of thousands of local engineering hours and in excess of 4 million test kilometers. We have met these new emission standards whilst still satisfying customer demand for continual improvements in power, fuel economy and productivity.

The T658 can be optioned with the most powerful engines from Caterpillar or Cummins, up to 625hp, making those heavy duty, long haulage operations a breeze.

And the redesigned cooling packages with over 20 per cent more area means these high output engines will run cool in the hottest operating conditions.

Off-highway versatility

Kenworth T658 trucks have been designed with demanding off-highway operating conditions particularly in mind.

The front axle has been set back for increased manoeuvrability and a tight turning circle required for logging and similar applications.

The high mounted cab is set back clear of the engine giving excellent access for easy maintenance and servicing in remote locations.

Mounting the cab higher also provides more flexibility in frame layout. Batteries can be located under the cab allowing a shorter wheelbase or longer range fuel tanks. Or batteries can be frame-mounted allowing space for toolboxes under the cab.

Driver comfort and safety

A lot of care has been taken to design the T658 cab to provide the highest levels of driver comfort and safety in the wide variety of applications in which this truck will be operating. The end result is less fatigue and higher operating efficiency.

The sloping hood offers excellent short distance forward vision in confined spaces, and Daylite doors with drop down glass sections provide improved side vision. Traditional doors are available as an option.

State-of-the-art cab comforts are further enhanced by improved airflow from the high cabin design reducing engine heat transfer to the cab. Long front springs provide the smoothest possible ride in all conditions, again reducing driver fatigue and increasing safety and efficiency.





Design flexibility

A wide choice of power options from North American engine manufacturers, as well as the best in transmissions and rear axles, means operators can spec their Kenworth T658 precisely to match its application.

The full range of Kenworth manufactured modular sleeper boxes are available in 915mm and 1270mm sizes, featuring flat or a range of aerodynamic roofs and/or fairings as required.

A range of suspension options can be specified, including Kenworth's smooth riding Airslide 400/460 units.

The rough and the smooth

Kenworth's T658 trucks are built tough and strong for the most rugged applications, but they also excel in smooth highway conditions. Supreme performance combined with the highest levels of comfort and safety make this one of the most versatile trucks on or off the road.

T658 Rugged Power